

# S.R Mechanical works.

An ISO 9001:2018 Certified Company

- ✉ e-mail : info@srmech.in, srmech@gmail.com, srmw\_77@yahoo.com
- 📞 Mobile : +91 - 9888030507, +91-9876160969, +91-9780378810
- 📍 53-54, Gokal Ka Bagh, East Mohan Nagar, AMRITSAR-143006

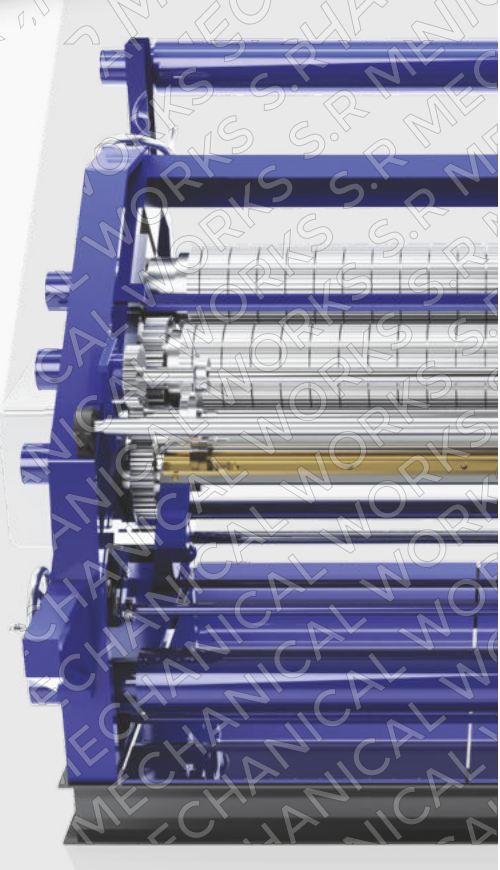

**Brass Guides and Rings**  
For Adequate burst Pressure

**Glue Applicator Rollers**

- Optional Machelical Engraved Surface
- Steel Cladded and Chrome

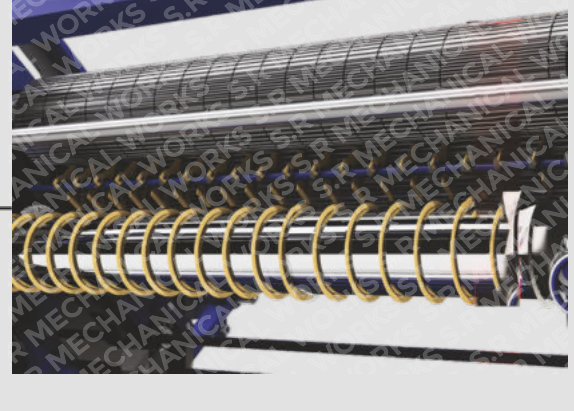

- Re winding Attachment with Two Shafts - tension control screw can be operated manually.

- Slitting Attachment Suitable for cutting & Slitting the edges of Corrugated Sheet Thanks to its cover Surface Design Winding Rewind roll can be produced with suprior results.

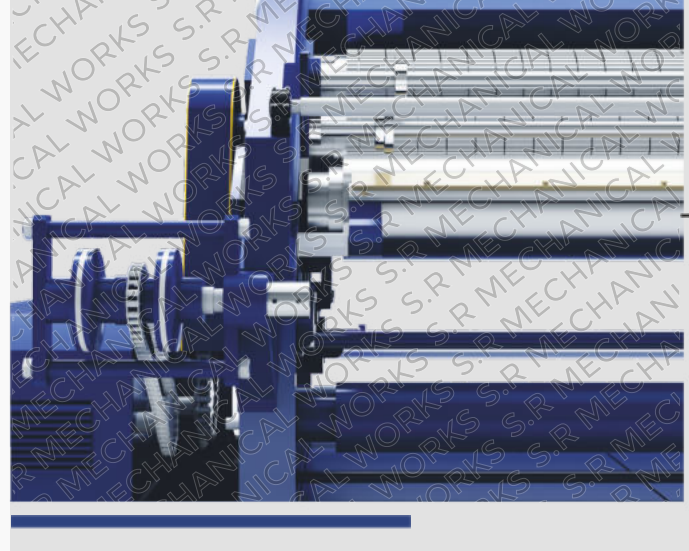

• **AISI - 1055 Carbon Steel Flute Rollers**

- 23024cc/w33 SKF Self Alling Rollar Bearing

- 440V/3 Phase : 11kw Each Nichrome 80/20 S.S 304 Heater

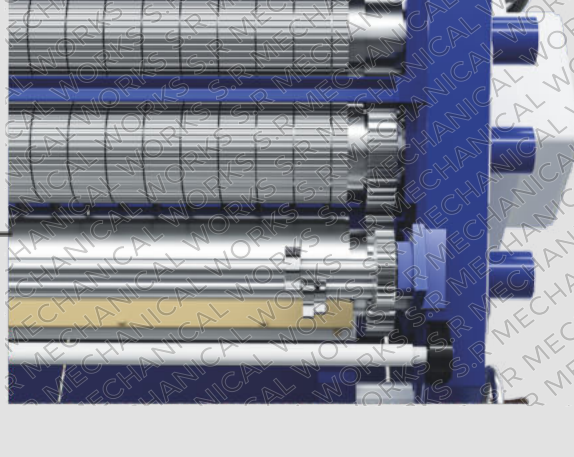

## HIGH SPEED BEARING MOUNTED TYPE CORRUGATION MACHINE

### Machine Specification

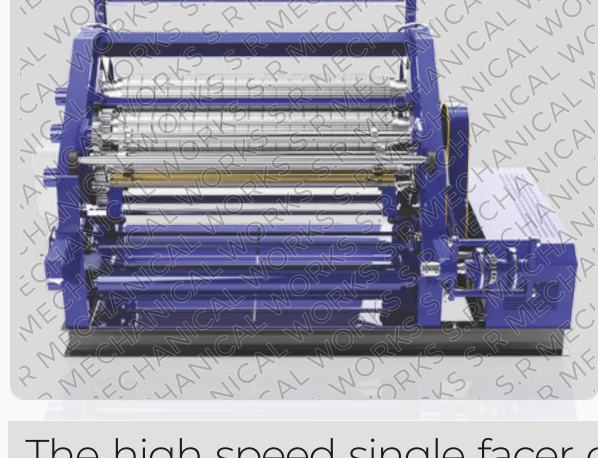

Size	54"	64"	74"
Output/min	130 ft. (Approx)	130 ft. (Approx)	130 ft. (Approx)
Power (HP).	7.5	7.5	10
Heating load (KW)	33	39	on steam

The high speed single facer offers a high rate of production and enhances efficiency. The rolls are mounted on roller bearing for smooth running and longer life. The rolls are made from specially EN19 forged material, The roll dia is approximately 233mm. Minutely finished flute rolls result in perfect formation of flutes. The machine is equipped with lead worm system to adjust the pressure roller and gum roller, which is opertaed from seprate adjustment wheel for single side and synchronized pressure.

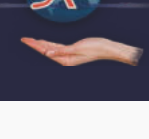

### PRODUCT BENIFITS



#### USER FRIENDLY OPERATION

This Machine Has been Built by Keeping Simplicity In Mind. It's Universal Control Panel Allows Anyone To Operate The Unit Without Any Technical Knowledge.



#### BRANDED COMPONENTS

Hydraulic Reel Stand Has Been Equipped With Branded Electrical, Pneumatic, And Mechanical Components Providing Maximum Efficiency & Minimum Downtime.



#### VALUE FOR MONEY

We Deliver Quality High - End Product That Are Quite Affordable And Will Not Let Cost Become A Major Factor While Setting Up Your Desired Board Plant.



#### ROBUST ENGINEERING

Built From High - Quality Components, This Machine is Designed to Work For Countless Hours Without Compromising With The Plant Performance And Speed.



#### MINIMUM CHANGEOVER TIME

High Quality A grade C.I casting is used Branded electricals like seimens, Heavy electro magnetic clutch laser sensor, bronze sulphate bushes EN9 cranks & Shafts, helical steel gears both inside and outside & Mechanical componests providing maximum efficiency & Minimum Downtime.



#### COMPLETELY MADE IN INDIA

This Machine is made & Assembled In India, Contributing Toward The Nation's Economy, Simultaneously Giving High - End Solution To The Indian Corrugators.

THANKS YOU FOR READING

### CONTACT US

- MOBILE NO.** +91-98880 30507, +91-98761 60969, +91-97803 78810
- PHONE NO.** +91-183-2580111, 5094678
- FAX** +91-183-2581717
- E-MAIL** info@srmech.in, srmech@gmail.com, srmw\_77@yahoo.com
- LOCATION** 53.54 Gokal ka Bagh, East Mohan Nagar, Amritsar-143006

### FOLLOW US ON



**FACEBOOK**  
SR Mechanical Works



**YOUTUBE**  
S R MECHANICAL WORKS



**INSTAGRAM**  
@S.R\_MECH



**WEBSITE**  
www.srmech.in

**S.R MECHANICAL WORKS** Manufactured & Exported